

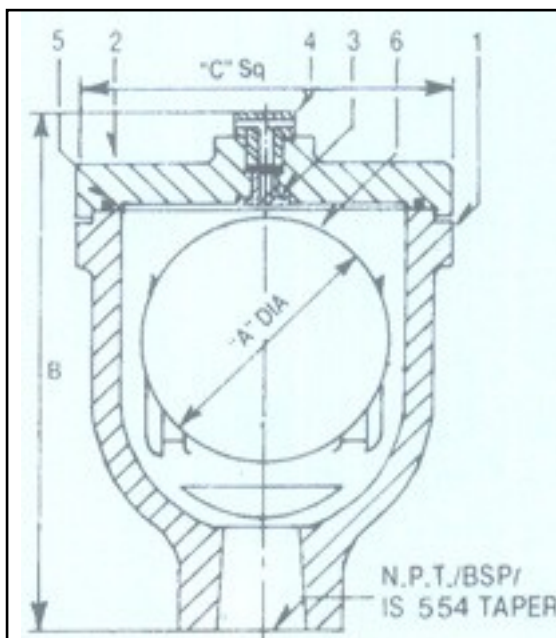

The air release valves shall maintain closed position to prevent the loss of water by the positive seating of a non – corrosive float against a smoothly ground contact surface of the exhaust orifice. It shall automatically provide for the special ball float moves away from the orifice seat. The float shall be free floating within the valve body, linkages or evers attached to the float are not acceptable. The body of the valve shall be cast iron.

INSTALLATION

Once in the system, air will tend to collect at summits in the pipeline and points where the pipe slops changes. Just as important as the proper selection o air release valves is the proper location and installation. Air pockets are generally found just downstream of the area where they are first suspected due to the velocity of the fluid. As a general rule required location of air release valves may be seen by referring to the drawing. A careful study will show that there is an air release valve at every change in the pipeline slope with the exception of the extreme low points.



		Dimension		
Model	Working Press	A	B	C
Uni - 150	10.98 kg/Cm2	50 MM	206.25 MM	143.75 MM
Uni - 300	21.96 kg/Cm2	87.5 MM	275 MM	175 MM

Parts List

1. BODY
2. HIGH PRESSURE COVER
3. HIGH PRESSURE ORIFICE
4. VENT PLUG
5. "O" RING
6. HIGH PRESSURE BALL

Uni – 4 furnished standard with 1/16" (1.56 mm) orifice. Other orifices are available where required. Consult factory for details.

WHY INSTALL?

ECONIMICS – To ensure that a pumping system will operate in the most efficient manner, care must be taken to ensure that trapped or entrained air is not robbing the system of the efficiency that the designer originally intended.

The presence of tapped air pockets can seriously reduce the carrying capacity of the line. In fact, air binding can completely stop the line flow. Air binding in pipelines requires additional power expenditures which can substantially increase the pumping costs. Thus, the proper application and selection of air release valves becomes an investment bringing immediate returns without major cost considerations.

AIR ENTRY

There are numerous ways in which air can enter a pipeline. A few common ways are:

1. Air that is in the line before the line is filled and not completely purged.
2. Well pump installations without air release valves can on startup add considerable air to the pipeline.
3. Air may be drawn in at intakes, for example, by the vortex action at a pump suction.
4. Air may be drawn into the line at leaking joints or glands.
5. Air in solution is released at high points in the line or at points of pressure reduction such as throttled valves or other restrictions.

Cast Iron Large Airrelease Valves

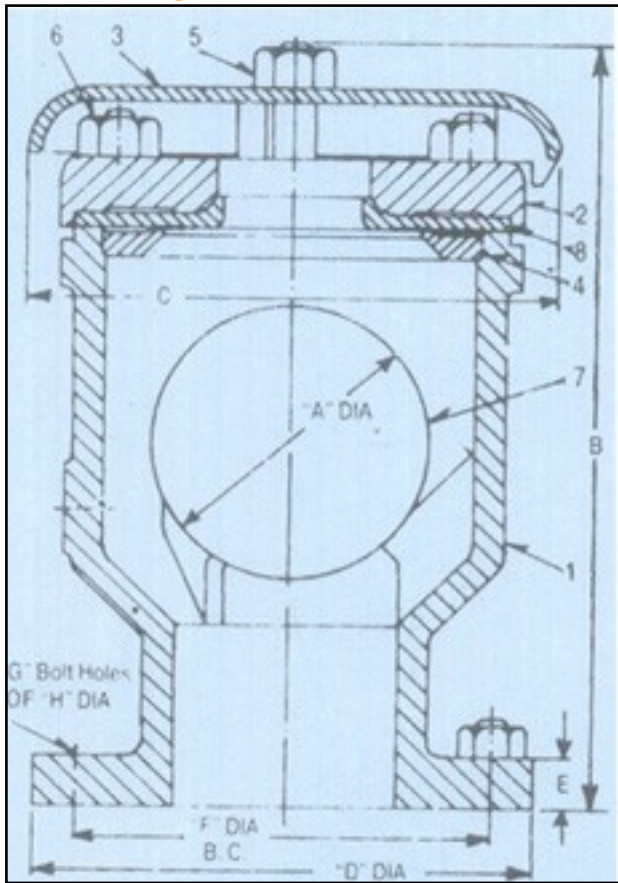

PART LIST

No.	Item	No.	Item
1	Body	5	Cowl Bolts
2	Cover	6	Cover Bolts
3	Cowl	7	Ball
4	Joint Support Ring	8	Seat Ring

Valve Size	A Ball Via	B Height	C Width	D Fig. Od.	E Fig. Thk.	F Bolt Circle	G No. Holes	H Hole Dia
25	51	201	157	Available Scr.	End.	Only		
50	76	263	188	151	16	119	100	19
75	97	282	244	188	19	151	100	19
100	126	357	304	226	23	188	200	19
150	201	482	426	276	26	238	200	22
200		576	501	338	28	294	200	22

Note : Flanges – dimensions given are for ASA class 125 ANSI 16.5 or may be as per IS/BS/DIN as required.

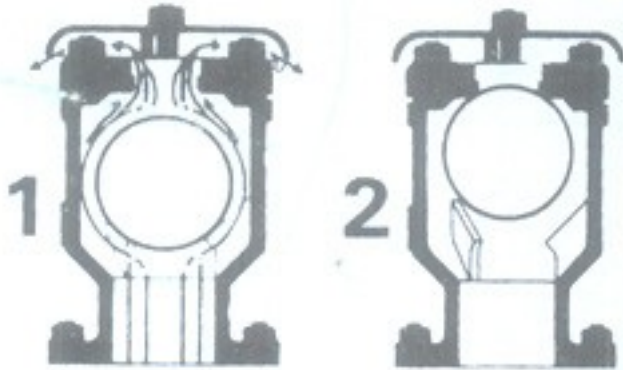

FEATURES

Only one moving part
 Non – corrosive, non collapsible float
 Drop – tight closure
 Highest discharge capacity
 Kinetic design prevents blowing shut

SPECIFICATIONS

The air release valve shall employ the kinetic operating principle with one moving part, a stainless steel buoy ball. The valve shall be designed such that when the large orifice is open, the ball remains in the throat area without the possibility of the valve blowing shut or collapsing the

NOTES:

1. 50 mm & 75 mm size valve available with screwed (N.P.T) or flanged ends on inlet.
2. Sizes to 10 mm are available with screwed (N.P.T) outlet and throttle devices for deep well pump service.

1. During the exhausting sequence, the air flowing around the buoy ball produces a resultant downward force which maintains the ball in the open position.

The buoyant force of the ball will seal the exhaust orifice when water reaches the ball.

ball. The valve shall close when water rises in the valve to lift the ball to the orifice seat. The valve body shall be cast iron.

Cast Iron Dynamic Air valves

RATING	P.N. 10	P.N. 16	P.N. 25
Body test pressure	15 bar	24 bar	38
Set test pressure	10 bar	16 bar	25
Ball test pressure	10 bar	16 bar	25

TEMPERATURE MAX.

LIQUID
400° C

AIR
700° C

FLANGES

TO B.S. 4504 or B.S. 10

DIRECTION OF OPENING

Anti clockwise unless otherwise specified

Materials

Body, Cover, Gland etc.
IS 210 FG 220
Trim, Nut & Disc
GM IS 318 LTB 2
Stem STB IS 320 / Alloy 2
Floats : Large coated by ebonite & small by Nitrile rubber on Seasoned wood or stainless steel.
Working parts may be supplied of stainless steel conforming to AISI 304

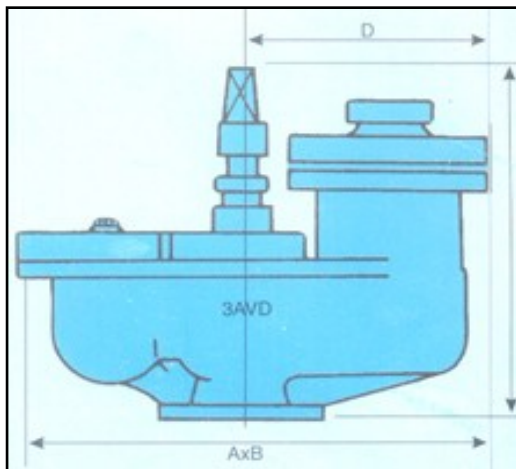

DIMENSIONS IN MILLIMETRES P.N. 16 Rating only.

Size	40	50	80	100	125	150	200
A	600	600	600	695	873	873	1071
B	258	258	258	322	423	423	517
C (Open)	492	492	492	512	660	660	776
D	295	295	295	377	511	511	636
Size of Ball	125	125	125	125	125	125	125
	100	100	100	125	200	200	280
Approx. wt. Kg 60	60	60	79	115	217	217	458
Flow curve Ref.	1	1	2	3	4	4	5

Note : Due to constant up gradation, dimensions are subject to change by the manufacturer.