

NON SLAM CHECK VALVE

SIZES: DN15 TO DN150

CLASS 150 | CLASS 300



FEATURES

- Non-Slam Disc Check Valve is an advanced design valve which gives full flow.
- Requires little space in pipes due to the compact design of valves.
- These valves are simple to fit between two pipe flanges.
- Stronger, lighter and smaller than conventional swing check valves, hence easy to install and maintain.
- Spring loaded disc to prevent reverse flow in pipe lines.
- Cam design on body diameter enables self-centering during installation.
- The valves can be mounted in any plane/direction in pipelines.
- Extremely Low operating pressure.
- Suitable for wide variety of liquids and vapors.

ISO 9001:2015

BUREAU VERITAS
Certification



TECHNICAL DATA :

DESIGN STANDARD : BS 7438 / API 6D
 TESTING & INSPECTION STANDARD : BS 5146 / API 598

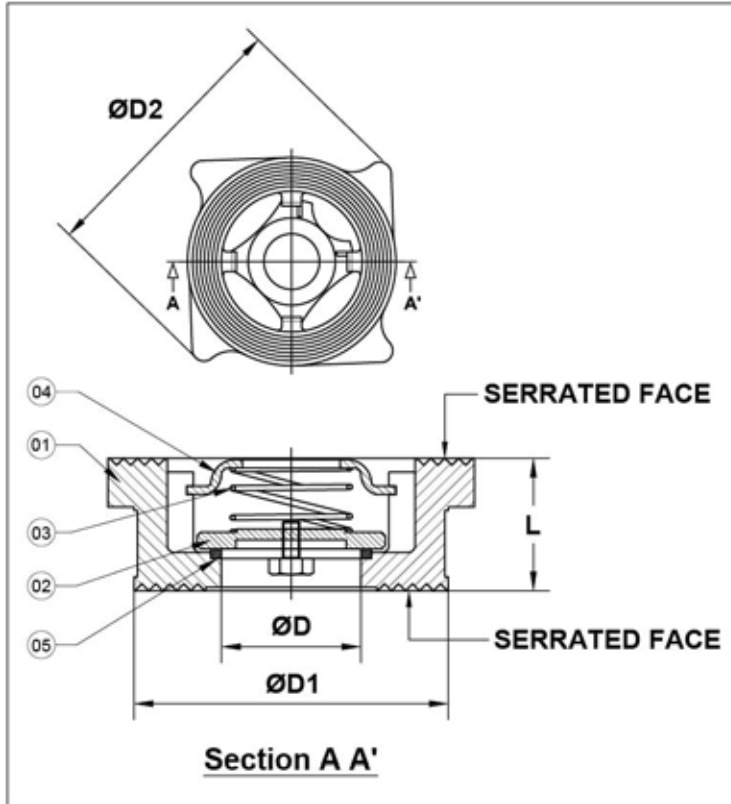

NO	DESCRIPTION	MATERIAL	QTY
1	BODY	ASTM A216 Gr.WCB ASTM A351 - CF8 ASTM A351 - CF8M	1
2	DISC	SS304 / SS316	1
3	SPRING	SS304 / SS316	1
4	RETAINER	AISI 304 / AISI 316	1
5	SEAT	METAL TO METAL	1

PRIMARY SERVICE RATING & TEST PRESSURE				
CLASS	WORKING PRESSURE	TEMP.	HYDROSTATIC TEST PRESSURE	
			BODY	SEAT
150	150 PSIG	500°F	425 PSIG	
300	300 PSIG	800°F	1100 PSIG	800 PSIG
AIR TEST - SEAT : 80 PSIG ± 10 PSIG				

SIZE		CLASS 300			
in.	mm	ØD	ØD1	ØD2	L
½"	15	15	38	60	16
¾"	20	20	47	70	20
1"	25	24	55	80	22
1 ½"	40	39	75	100	32
2"	50	50	93	115	40
2 ½"	65	65	109	142	46
3"	80	76	127	154	50
4"	100	98	148	184	60
6"	150	150	202	230	74

ALL DIMENSIONS ARE IN MM UNLESS OTHERWISE SPECIFIED

REGISTERED FACTORY AND OFFICE
ROYALTECH VALVES
 #B-492/B, 2ND GATE INDUSTRIAL ESTATE
 GOKUL ROAD, HUBLI-580030
 KARNATAKA, INDIA

FOR ENQUIRY, CONTACT US AT

+91 90198 20791 | 97383 48007

sales.royaltechvalves@gmail.com

FOR FURTHER DETAILS, VISIT OUR WEBSITE

www.royaltechvalves.com