

## FORGED STEEL GLOBE VALVE (SCREWED END | SOCKETWELD END)

**SIZES: DN15 TO DN50**

**CLASS 800**



### FEATURES

- Body & Bonnet made from high quality forging.
- The Forgings are precision machined for high performance.
- Forged Steel Globe Valves are generally available with Plug Type Disc, which is designed to give leak tight seating over a long period of in built wear life.
- Stem is made from solid one piece construction.
- The yoke bush of Globe Valve has a long thread engagement for accurate stem alignment.
- Leak Proof Body-Bonnet Joint With Spiral Wound Gasket
- Rising Stem & Rising Hand Wheel Construction.
- Self Aligning Two Piece Gland.
- Precision Stem Packing Chamber.
- Deep stuffing box is providing for tightness and maximum long packing life.
- Swinging Eye Bolts facilitate easy access to the stuffing box.
- Back seating feature facilitates repacking of the stuffing box on line with the valve in fully open position.
- Screwed NPT, BSP, BSPT and Socket Weld end connections are available.

ISO 9001:2015

**BUREAU VERITAS**  
Certification



## TECHNICAL DATA :

MANUFACTURING STANDARD : BS 5352  
 TESTING & INSPECTION STANDARD : API 598  
 SOCKETWELD AND THREADED TO : ASME B16.11 / ASME B1.20.1  
 FLANGE TO FLANGE DISTANCE : ASME B16.10

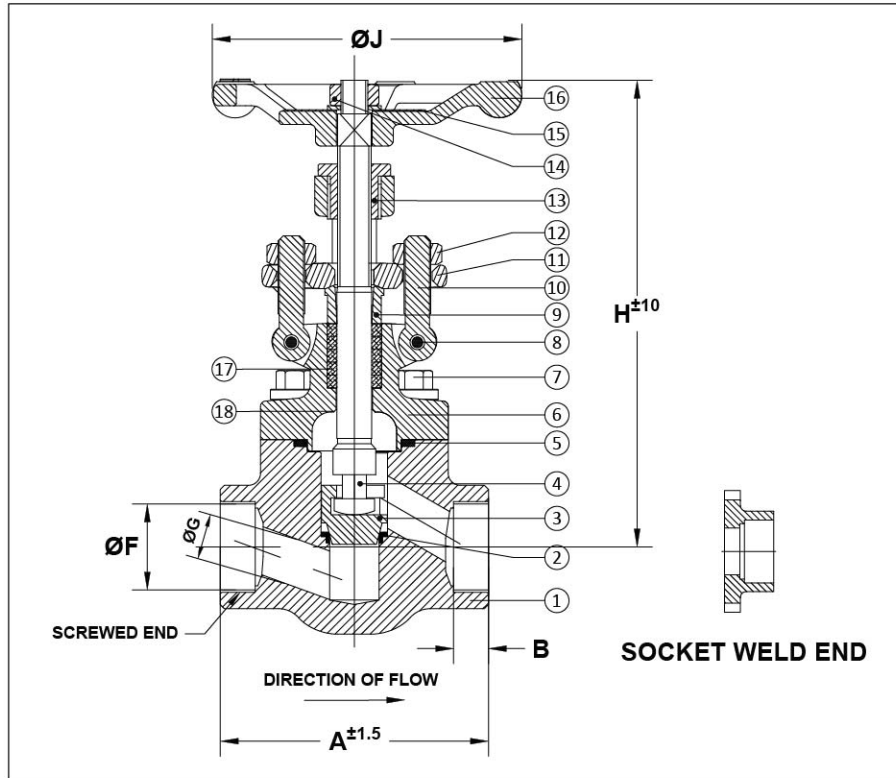

NO	DESCRIPTION	MATERIAL	QTY
1	BODY	A105 / F304 / F316 / F11 / F22	1
2	SEAT RING	AISI 304 / AISI 316 / 13% Cr. SS	2
3	PLUG	AISI 304 / AISI 316 / 13% Cr. SS	1
4	STEM	AISI 304 / AISI 316 / 13% Cr. SS	1
5	GASKET	SPIRAL WOUND SS304 WITH CAF	1
6	BONNET	A105 / F304 / F316 / F11 / F22	1
7	HEX BOLT	ASTM A193 Gr.B7	4
8	EYE BOLT PIN	ASTM A276 Type SS410	2
9	GLAND BUSH	AISI 304 / AISI 316 / 13% Cr. SS	1
10	EYE BOLT	FORGED CS	2
11	GLAND FLANGE	ASTM A105	1
12	EYE BOLT NUT	FORGED CS	2
13	YOKE SLEEVE	AL. BRONZE / NI-RESIST	1
14	STEM NUT	CARBON STEEL	1
15	NAME PLATE	STAINLESS STEEL	1
16	HAND WHEEL	CAST IRON / CS	1
17	GLAND PACKING	SS METAL WIRE BRAIDED ASBESTOS	5
18	BACK SEAT	ASTM A105N INTEGRAL	---

SIZE		CLASS 800					
in.	mm	A	B	ØF	ØG	H	ØJ
½ "	15	85	10	22	9	150	78
¾ "	20	90	13	27.5	12	165	78
1 "	25	105	13	34	17.5	185	100
1 ½ "	40	128	13	48.6	29.5	239	142
2 "	50	142	16	61.1	35	248	142

ALL DIMENSIONS ARE IN MM UNLESS OTHERWISE SPECIFIED

TEST PRESSURE	
BODY	SEAT
3000 PSIG	2000 PSIG
AIR TEST OF SEAT AT 100 PSIG	

**REGISTERED FACTORY AND OFFICE**  
**ROYALTECH VALVES**  
 #B-492/B, 2ND GATE INDUSTRIAL ESTATE  
 GOKUL ROAD, HUBLI-580030  
 KARNATAKA, INDIA

**FOR ENQUIRY, CONTACT US AT**

+91 90198 20791 | 97383 48007

sales.royaltechvalves@gmail.com

**FOR FURTHER DETAILS, VISIT OUR WEBSITE**

www.royaltechvalves.com